

**BRASS CHECK VALVE WITH STRAINER BASKET**



**Size :** DN 1/2" to 4"  
**Ends :** Female BSP  
**Min Temperature :** + 0°C  
**Max Temperature :** + 65°C  
**Max Pressure :** 16 Bars ( up to DN 1" )  
**Specifications :** All positions  
Stainless steel strainer  
Nylon throttle

**Materials :** Brass body

**BRASS CHECK VALVE WITH STRAINER BASKET**

**SPECIFICATIONS :**

- Respect the flow direction indicated by the arrow
- Stainless steel strainer
- All positions with SS 304 spring
- Female type, BSP threaded
- Nylon throttle
- Weak head loss thanks to the cylindrical internal designing
- Low pressure opening
- Double axial and lateral guide for a better centering of the throttle on the seat
- NBR gasket for a better tightness for high and low pressure
- Mesh 2 mm

**USE :**

- Water supply, water distribution and drainage
- Min Temperature Ts : + 0°C
- Max Temperature Ts :+ 65°C
- Max Pressure Ps : 16 bars up to DN 1" , 10 bars from DN 1"1/4 to 2" and 8 bars over

**HEAD LOSS GRAPH :**

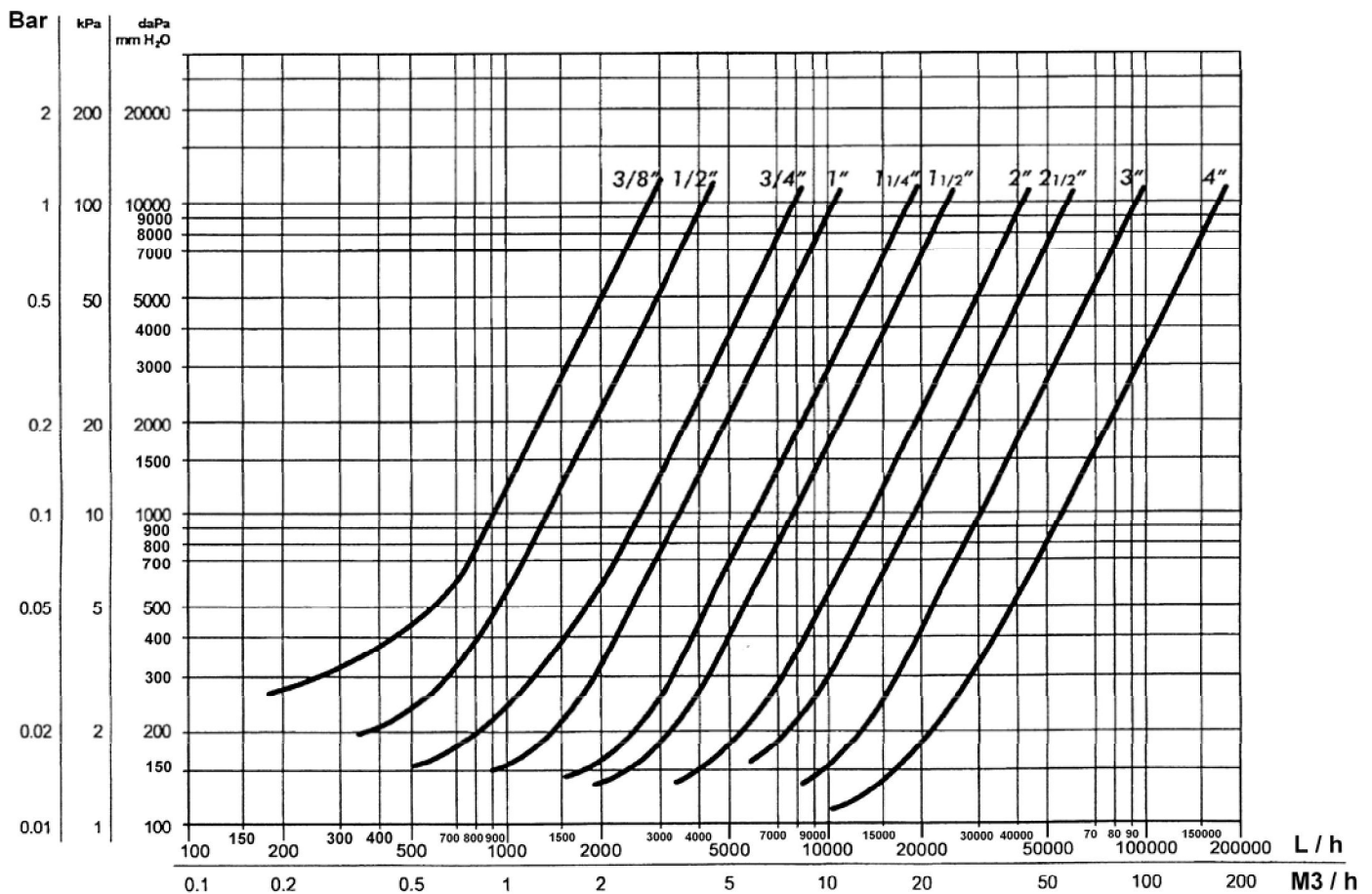

**BRASS CHECK VALVE WITH STRAINER BASKET**

**OPENING PRESSURE :**

- Opening pressure between 20 and 200 mbar

**RANGE :**

- Threaded BSP cylindrical ends from DN 1/2" to DN 4"

**MATERIALS :**

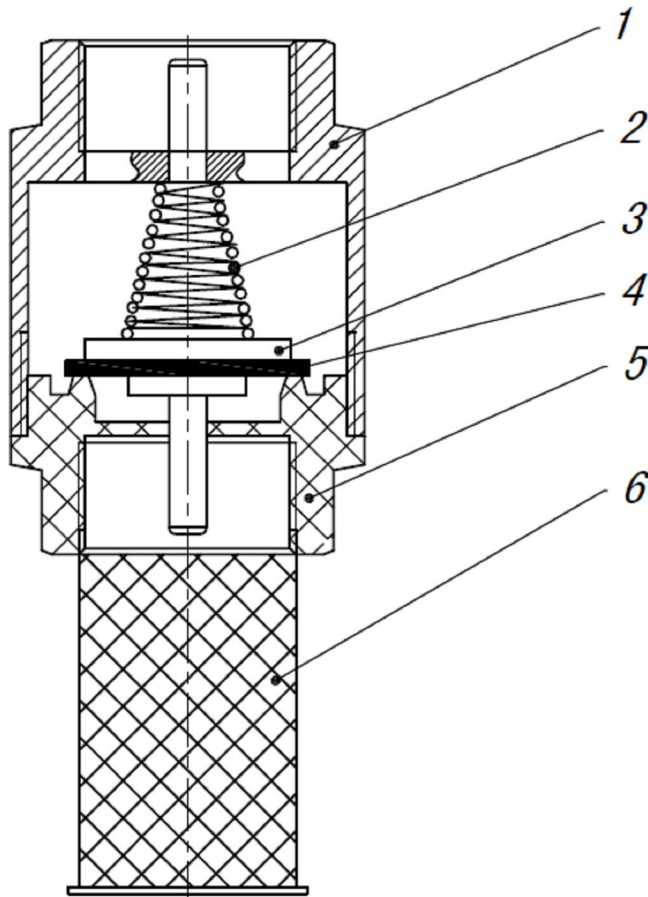

Item	Designation	Materials
1	Body	Brass
2	Spring	AISI 304
3	Throttle	Nylon
4	Gasket	NBR
5	Bonnet	ABS
6	Strainer	AISI 304

**BRASS CHECK VALVE WITH STRAINER BASKET**

SIZE ( in mm ) :

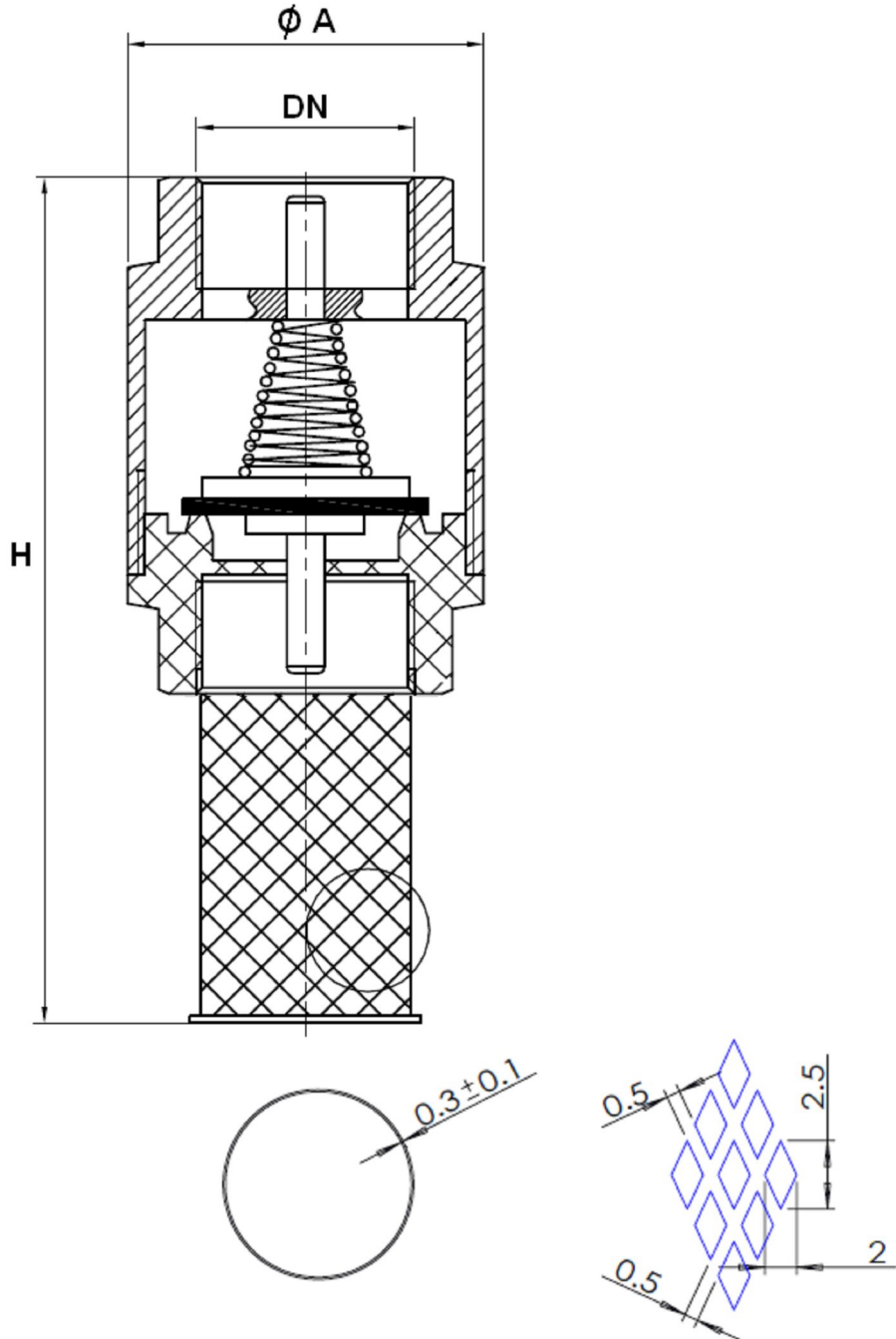

Ref.	DN	1/2"	3/4"	1"	1"1/4	1"1/2	2"	2"1/2	3"	4"
311	Ø A	32.5	42.5	47.5	57.5	68	80.5	102	111	140
	H	66	75	86	100	111	130	155	168	185
	Weight ( Kg )	0.08	0.12	0.16	0.22	0.33	0.5	1.02	1.35	1.85

**BRASS CHECK VALVE WITH STRAINER BASKET****STANDARDS :**

- Fabrication according to ISO 9001 :2008
- DIRECTIVE 97/23/CE : Products excluded from directive (article 1, § 3.2)
- Threaded female BSP cylindrical ends according to ISO 228-1

**ADVICE :** Our opinion and our advice are not guaranteed and SFERACO shall not be liable for the consequences of damages. The customer must check the right choice of the products with the real service conditions.

## BRASS CHECK VALVE WITH STRAINER BASKET

### INSTALLATION INSTRUCTIONS

#### GENERAL GUIDELINES :

- Ensure that the check valves to be used are appropriate for the conditions of the installation (type of fluid, pressure and temperature).
- Be sure to have enough valves to be able to isolate the sections of piping as well as the appropriate equipment for maintenance and repair.
- Ensure that the valves to be installed are of correct strength to be able to support the capacity of their usage.

#### INSTALLATION INSTRUCTIONS :

- **Before installing the check valves, clean and remove any objects from the pipes** (in particular bits of sealing and metal) which could obstruct and block the valves.
- **Ensure that both connecting pipes either side of the check valve (upstream and downstream) are aligned (if they're not, the valves may not work correctly).**
- **Make sure that the two sections of the pipe (upstream and downstream) match, the check valve unit will not absorb any gaps. Any distortions in the pipes may affect the tightness of the connection, the working of the check valve and can even cause a rupture.** To be sure, place the kit in position to ensure the assembling will work.
- Before starting the fitting, ensure that the threads and tapping are clean.
- **If sections of piping do not have their final support in place, they should be temporarily fixed. This is to avoid unnecessary strain on the check valve.**
- The theoretical lengths given by ISO/R7 for the tapping are typically longer than required, the length of the thread should be limited, and **check that the end of the tube does not press right up to the head of the thread.**
- When screwing the check valve, ensure that you only rotate on screwed side by the 6 ended side. Use an open ended spanner or an adjustable spanner and not a monkey wrench.
- **Never use a vice to tighten the fixings of the check valve.**
- Do not over tighten the check valve. Do not block with any extensions as it may cause a rupture or weakening of the casing.
- **In general, for all check valves used in buildings and heating, do not tighten above a torque of 30 Nm.**
- If there is a direction changing or if there's another material, it's better to take away the check valve so that it is outside the turbulence area ( **between 3 and 5 times the ND before and after** ).
- After a pump please refer to **FD CEN/TR 13932** to install the check valve :
  - If it is essential to keep priming the pump, a non-return check valve can be fitted to the suction pipe at a distance **L1 ( straight length suction ) > 10xD1 ( diameter suction )**  
The check valve is designed to meet the maximum flow rate in service
  - In other cases, the non-return check valve is mounted on the discharge pipe at a distance of **L2 (straight length at discharge) > 3xD2 (diameter at discharge)**