

CDA

DUAL IMPELLER CENTRIFUGAL ELECTRIC PUMPS

in cast iron



PERFORMANCE CURVES (according to ISO 9906 Attachment A)

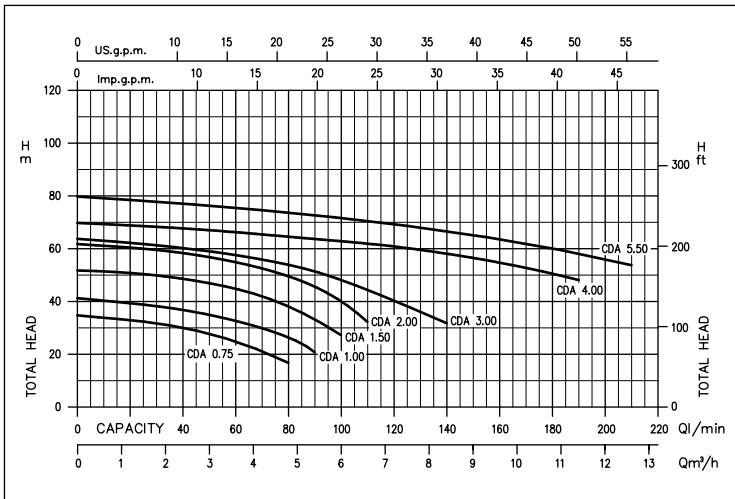

IDENTIFICATION CODE

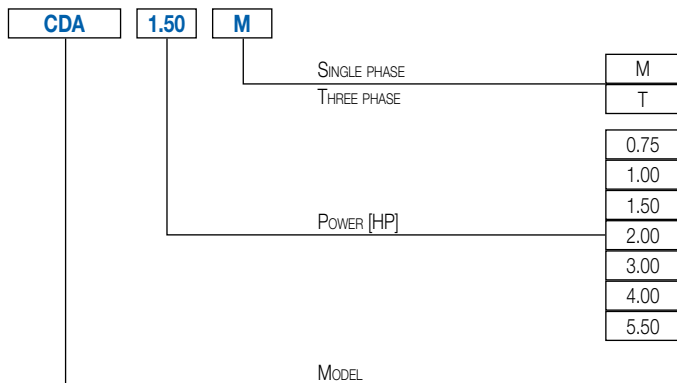

Cast iron dual impeller centrifugal electric pumps.

APPLICATIONS

- Pressure boosting domestic plants
- Small-scale irrigation
- Pumping non-aggressive liquids for civil and industrial use
- Washing plants
- Washing vehicles

TECHNICAL DETAILS

- Available with brass impeller (CDA 0.75 M GO, CDA 1.00 M/T GO)
- They can be inserted into machinery for industrial use

PUMP TECHNICAL DATA

- Maximum working pressure: 6 bar for CDA 0.75 - 1.00, 10 bar for the rest of the range
- Maximum temperature of the liquid: 40°C for CDA 0.75 - 1.00, 90°C for the rest of the range
- Suction connection G1 for CDA 0.75 - 1.00, G1¼ for CDA 1.50 - 2.00 - 3.00, G1½ for CDA 4.00 - 5.50
- Discharge connection: G1 for CDA 0.75 - 1.00 - 1.50 - 2.00 - 3.00, G1¼ for CDA 4.00 - 5.50

MOTOR TECHNICAL DATA

- High efficiency motors IE2 motors starting from 0.75kW up to 5.5kW IE3 starting from 0.75kW
- Self-ventilated 2 pole asynchronous motor
- Class of insulation F
- IP44 Protection degree
- 230V ± 10% 50Hz single phase voltage, 230/400V ± 10% 50Hz three phase voltage
- Permanent capacitor inserted and thermo-amperometric protection with automatic rearm incorporated for the single phase motor
- Protection under user's responsibility for the three phase version

MATERIALS

- Cast iron pump casing
- Mechanical seal in Ceramic/Carbon/NBR
- Impeller in PPE + PS reinforced with glass fibres for CDA 0.75-1.00, in brass for the rest of the range
- Shaft in AISI 303 for CDA 0.75 - 1.00 - 1.50 - 2.00 - 3.00, in AISI 304 for CDA 4.00 - 5.50
- Bracket in aluminium for CDA 0.75-1.00, in cast iron for the rest of the range
- Seal housing disc in AISI 304 for CDA 0.75-1.00, in cast iron built-in the motor bracket for the rest of the range

ACCESSORIES (On request)

- Electric panels
- Vessels
- Floats
- Pressure switches
- Presscomfort - Pressure regulator
- E-power - Variable speed control system
- E-drive - Variable speed control system

DUAL IMPELLER CENTRIFUGAL ELECTRIC PUMPS

in cast iron

PERFORMANCE CHART

Model		P ₂		Q = Flow Rate													
Single phase 230V	Three phase 230/400V	[HP]	[kW]	l/min	20	40	50	80	90	100	110	140	170	190	210		
				m ³ /h	1.2	2.4	3	4.8	5.4	6	6.6	8.4	10.2	11.4	12.6		
				H=Head [m]													
CDA 0.75 M	CDA 0.75 T	0.75	0.55	33.0	30.2	27.9	17.0	-	-	-	-	-	-	-	-		
CDA 1.00 M	CDA 1.00 T	1	0.75	39.5	37.0	35.2	27.0	21.0	-	-	-	-	-	-	-		
CDA 1.50 M	CDA 1.50 T	1.5	1.1	50.8	48.8	47.1	38.4	33.4	27.5	-	-	-	-	-	-		
CDA 2.00 M	CDA 2.00 T	2	1.5	60.5	58.6	56.9	49.8	46.5	40.3	32.5	-	-	-	-	-		
-	CDA 3.00 T	3	2.2	-	60.5	59.3	54.1	51.6	48.4	44.6	32.0	-	-	-	-		
-	CDA 4.00 T	4	3	-	-	67.0	64.8	63.9	62.5	62.0	58.0	53.5	48.0	-	-		
-	CDA 5.50 T	5.5	4	-	-	76.5	73.9	72.9	71.8	70.5	66.8	62.0	58.3	54.0	-		

DIMENSIONS

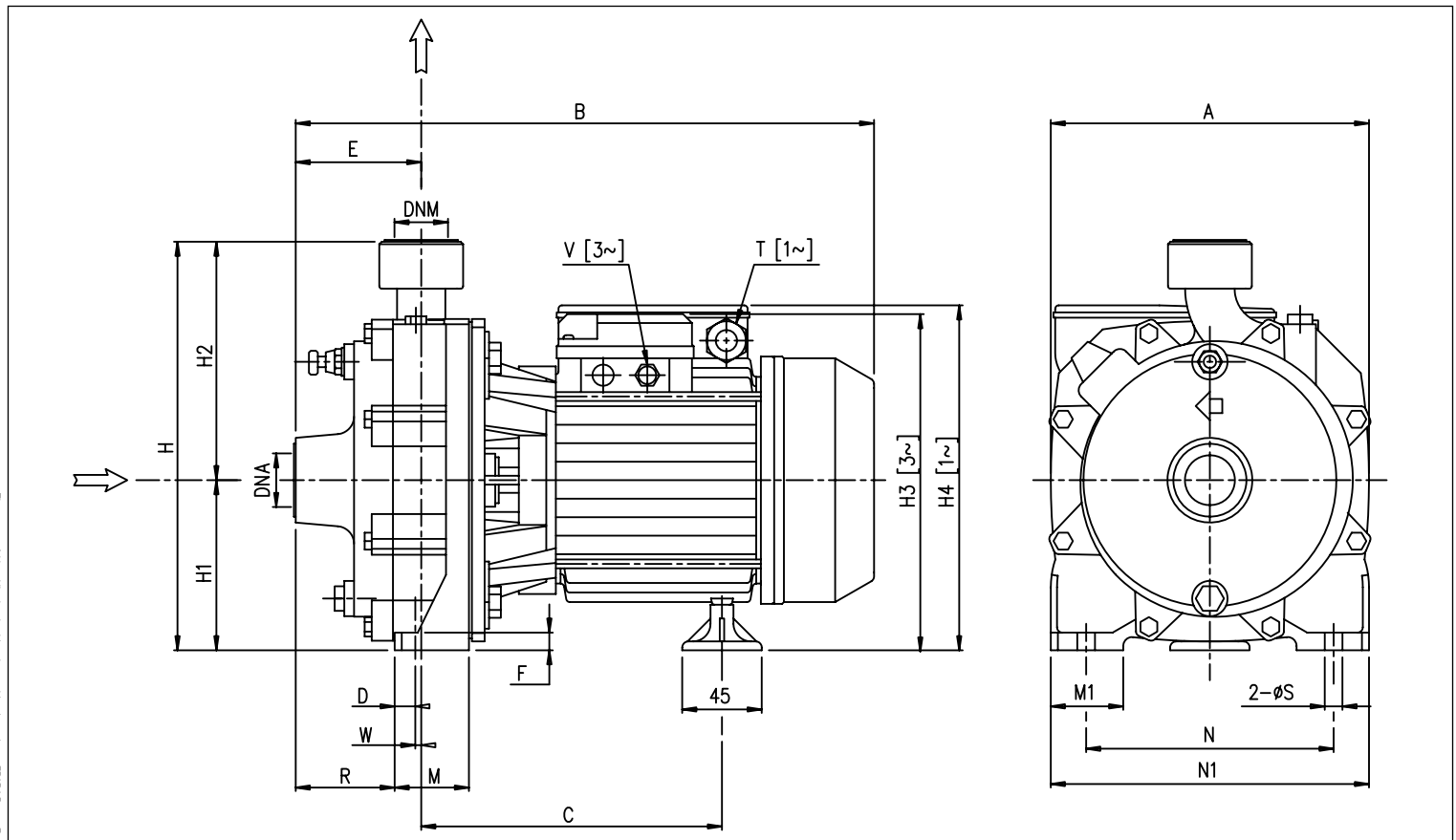

DIMENSIONAL TABLE

Model	Dimensions [mm]																				Weight [kg]								
	A	B *	C *	D	E	F	H	H1	H2	H3 [1]	H4 [2]	M	M1	N	N1	R	T [2]	V *	W	S	DNA/DNM	Weight [kg] *							
CDA 0.75M	183	336.3	-	179.8	-	8.3	73	9	227	97	130	-	-	198	42	40	140	180	57.5	PG11	-	-	6.8	9.5	G1	G1	13.8	-	
CDA 0.75T	183	336.3	-	179.8	-	8.3	73	9	227	97	130	197.5	-	-	42	40	140	180	57.5	-	PG11	-	-	6.8	9.5	G1	G1	13.8	-
CDA 1.00M	183	336.3	-	179.8	-	8.3	73	9	227	97	130	-	-	198	42	40	140	180	57.5	PG11	-	-	6.8	9.5	G1	G1	15.0	-	
CDA 1.00T	183	336.3	336.3	179.8	179.8	8.3	73	9	227	97	130	197.5	197.5	-	42	40	140	180	57.5	-	PG11	M16x1.5	6.8	9.5	G1	G1	15.0	15.0	
CDA 1.50M	209	407.8	-	218.3	-	8.3	86	9	265	110	155	-	-	242	48	40	155	195	65.5	PG13.5	-	-	12.3	9.5	G1¼	G1	24.2	-	
CDA 1.50T	194	394.8	419.8	218.3	218.3	8.3	86	9	265	110	155	224	224	-	48	40	155	195	65.5	-	PG11	M20x1.5	12.3	9.5	G1¼	G1	24.9	25.8	
CDA 2.00M	209	410.8	-	218.3	-	8.3	86	9	265	110	155	-	-	242	48	40	155	195	65.5	PG13.5	-	-	12.3	9.5	G1¼	G1	26.0	-	
CDA 2.00T	194	408	420.5	218.3	218.3	8.3	86	9	265	110	155	224	224	-	48	40	155	195	65.5	-	PG11	M20x1.5	12.3	9.5	G1¼	G1	27.1	28.0	
CDA 3.00T	194	410.8	423.3	218.3	218.3	8.3	86	9	265	110	155	224	224	-	48	40	155	195	65.5	-	PG11	M20x1.5	12.3	9.5	G1¼	G1	25.8	26.7	
CDA 4.00T	228	461.5	494.5	225.3	225.3	12	95.5	12	308.5	133.5	175	264.5	259.5	-	57	50	180	230	71.5	-	G1½	M20x1.5	12	12	G1¼	G1¼	46.8	46.8	
CDA 5.50T	228	508	508	225.3	225.3	12	95.5	12	308.5	133.5	175	264.5	264.5	-	57	50	180	230	71.5	-	G1½	M20x1.5	12	12	G1¼	G1¼	52.0	52.0	

[1]= Three-phase only [2]= Single phase only
* Models with IE3 motor only

DUAL IMPELLER CENTRIFUGAL ELECTRIC PUMPS

in cast iron

SECTIONAL VIEW

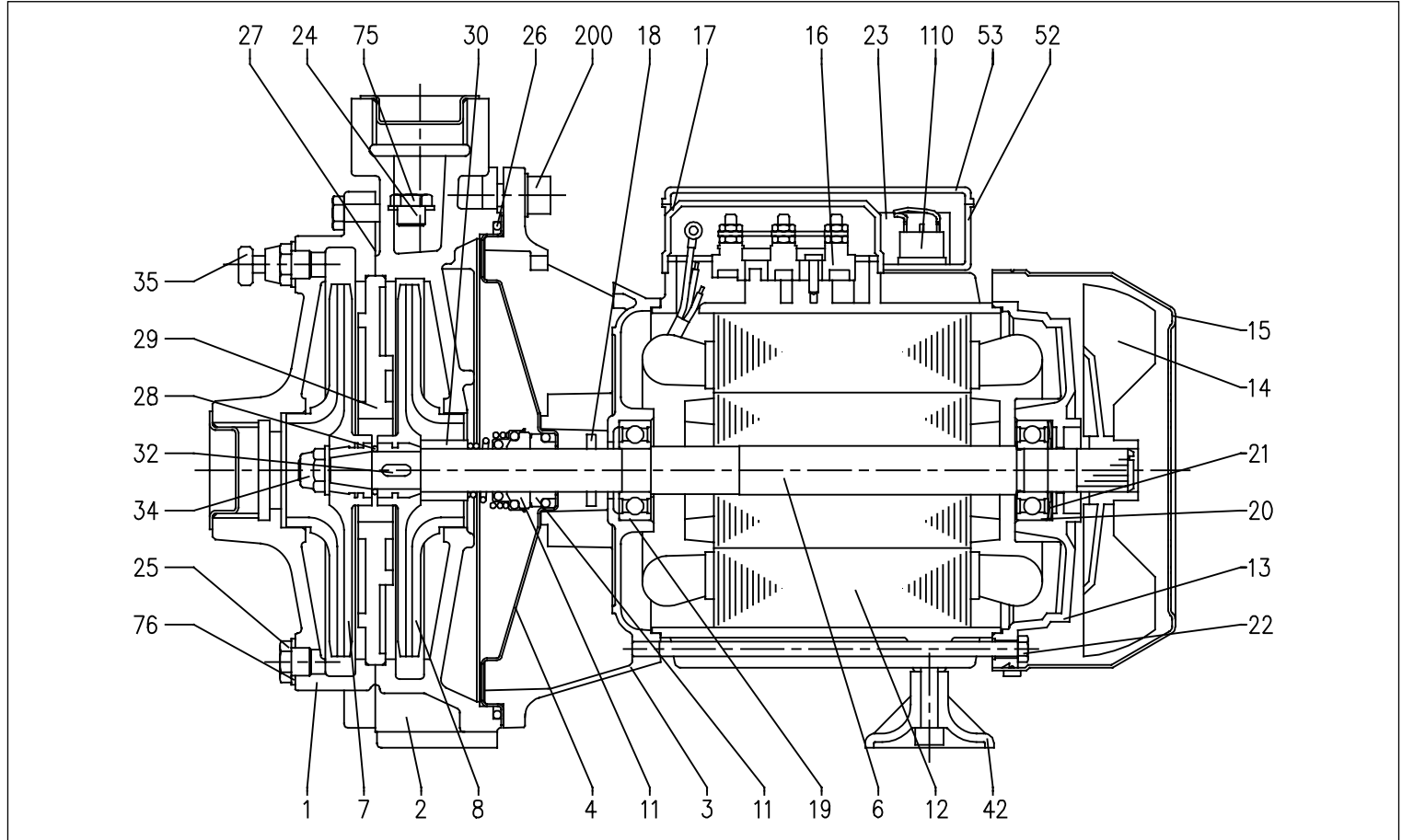

MATERIALS TABLE

Ref.	Name	Materials	Ref.	Name	Materials
1	Pump casing	Cast iron	23	Capacitor [2]	-
2	Pump casing	Cast iron	24	Plug	Brass
3	Motor bracket	[3]	25	Plug	Brass
4	Casing cover	[4]	26	O-Ring	NBR
6	Shaft	[5]	27	Pump body gasket	Cellulose fibres included
7	Impeller	[6]	28	O-Ring	NBR
8	Impeller	[6]	29	Intermediate disc	Cast iron
11	Mechanical seal	Ceramic/Carbon/NBR	30	Seal spacer	Brass
12	Motor frame	-	32	Key	AISI 316
13	Motor cover	Aluminium	34	Impeller nut [7]	AISI 304
14	Fan	PP	35	Bleed valve	Brass
15	Fan cover	Galvanised Fe P04	42	Motor support	PP
16	Terminal Box	-	52	Capacitor-holder box [2]	ABS
17	Terminal Box cover [1]	Aluminium	53	Capacitor-holder box cover [8]	ABS
18	Splash ring	NBR	75	Washer	Aluminium
19	Bearing (pump side)	-	76	Washer	Aluminium
20	Bearing (motor side)	-	110	Motor protector [9]	-
21	Adjustment ring	Steel C70	200	Screw (pump body)	Zn. steel Cl. 8.8 ISO 898-1
22	Tie-rod	Galvanised Fe 42			

[1]= Three-phase only

[2]= Single phase only

[3]= Aluminium for CDA 0.75 - 1.00, cast iron for the rest of the range

[4]= AISI 304 for CDA 0.75 - 1.00, cast iron integrated Motor support for the rest of the range

[5]= AISI 303 (part in contact with the liquid) for CDA 0.75 - 1.00 - 1.50 - 2.00 - 3.00, AISI 304 (part in contact with the liquid) for the rest of the range

[6]= PPE+PS reinforced with fibreglass for CDA 0.75 - 1.00, brass for the rest of the range

[7]= Version with brass impeller only

[8]= With gasket in NBR only for CDA 0.75 - 1.00 single phase models

[9]= Version CDA 1.50 - 2.00 single phase only

DUAL IMPELLER CENTRIFUGAL ELECTRIC PUMPS

in cast iron

MECHANICAL SEAL

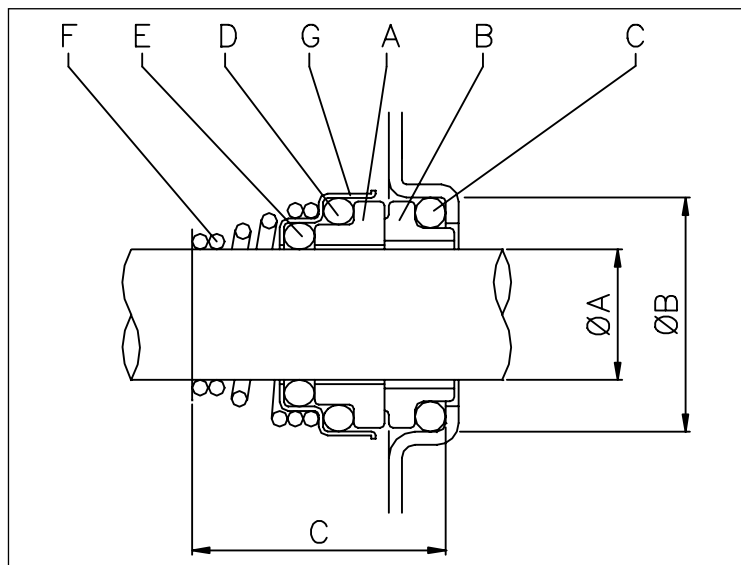

MATERIALS TABLE

Ref.	Name	Materials
A	Rotating part	Ceramic
B	Fixed part	Carbon
C	O-Ring	NBR
D	O-Ring	NBR
E	O-Ring	NBR
F	Spring	AISI 316
G	Structure/frame	AISI 304

DIMENSIONS

Single phase	Three phase	ØA	ØB	C
CDA 0.75 M	CDA 0.75 T	15	26	29
CDA 1.00 M	CDA 1.00 T	15	26	29
CDA 1.50 M	CDA 1.50 T	18	30.9	32
CDA 2.00 M	CDA 2.00 T	18	30.9	32
-	CDA 3.00 T	18	30.9	32
-	CDA 4.00 T	20	30.9	33
-	CDA 5.50 T	20	30.9	33

ELECTRIC DATA TABLE

Model	Single phase 230V	Three phase 230/400V	P ₂		Efficiency		Capacitor		Efficiency (%)			P ₁		Absorbed Current	
			[HP]	[kW]	Single phase	Three phase	Single phase µF	V _c	Three phase η %			Single phase [kW]	Three phase [kW]	Single phase 230V [A]	Three phase 230V 400V [A]
									50%	75%	100%				
CDA 0.75 M	CDA 0.75 T	0.75	0.55	-	-	16	450	-	-	-	1.1	1.05	5.0	3.4	2.0
CDA 1.00 M	CDA 1.00 T	1	0.75	-	IE2	20	450	77.2	80.9	81.3	1.38	1.13	6.1	3.4	2.0
-	-	1	0.75	-	IE3	-	-	80.9	82.3	82.1	-	0.91	-	3.0	1.7
CDA 1.50 M	CDA 1.50 T	1.5	1.1	-	IE2	40	450	79.7	82.5	83.0	1.85	1.80	8.6	5.5	3.2
-	-	1.5	1.1	-	IE3	-	-	83.0	85.8	85.6	-	1.77	-	5.8	3.3
CDA 2.00 M	CDA 2.00 T	2	1.5	-	IE2	40	450	80.3	83.4	83.8	2.35	2.25	10.8	7.8	4.5
-	-	2	1.5	-	IE3	-	-	84.2	86.8	86.9	-	2.01	-	7.1	4.1
-	CDA 3.00 T	3	2.2	-	IE2	-	-	83.0	84.4	83.8	-	2.74	-	8.5	4.9
-	-	3	2.2	-	IE3	-	-	86.2	87.0	86.0	-	2.55	-	8.2	4.7
-	CDA 4.00 T	4	3	-	IE2	-	-	83.1	86.3	86.8	-	4.10	-	12.5	7.2
-	-	4	3	-	IE3	-	-	85.9	87.5	87.1	-	3.44	-	11.1	6.4
-	CDA 5.50 T	5.5	4	-	IE2	-	-	84.3	87.2	87.8	-	4.56	-	15.1	8.7
-	-	5.5	4	-	IE3	-	-	85.8	88.3	88.4	-	4.52	-	15.1	8.7

NOISE DATA TABLE

Model	Single phase 230V	Three phase 230/400V	P ₂		L _{pa} - dB(A)*
			[HP]	[kW]	
CDA 0.75 M	CDA 0.75 T	0.75	0.55	<70	
CDA 1.00 M	CDA 1.00 T	1	0.75		
CDA 1.50 M	CDA 1.50 T	1.5	1.1		
CDA 2.00 M	CDA 2.00 T	2	1.5		
-	CDA 3.00 T	3	2.2		
-	CDA 4.00 T	4	3		
-	CDA 5.50 T	5.5	4		

* Mean value of several measurements at 1 m distance around the pump.

Tolerance ± 2.5 dB.