



Construction

Horizontal multi-stage close coupled pumps in chrome-nickel stainless steel.
 Compact and robust construction, with compact lantern bracket and motor with feet.
 Single-piece barrel casing, with front suction port above pumps axis and radial delivery at top.
 Filling and draining plugs on the middle of the pump, accessible from any side (like the terminal box).

Version with frequency converter (on request)

Applications

For water supply.
 For clean liquids, without abrasives, which are non-aggressive for stainless steel (with suitable seal materials, on request).
 Universal pump, for civil and industrial applications, for garden use and irrigation.

Operating conditions

Liquid temperature from - 15 °C to + 110 °C.
 Ambient temperature up to 40 °C.
 Maximum permissible pressure in the pump casing: 10 bar.

Motor

2-pole induction motor, 50 Hz ($n \approx 2900$ rpm).
 MXH: three-phase 230/400 V $\pm 10\%$ up to 3 kW;
 400/690 V $\pm 10\%$ from 4 to 7,5 kW.
 Insulation class F. Protection IP 54.
 Motor suitable for operation with frequency converter.
 Classification scheme IE3 for three-phase motors from 0,75 kW.
 Constructed in accordance with: EN 60034-1;
 EN 60034-30.

Materials

Component	Material
Pump casing	Chrome-nickel steel 1.4301 EN 10088 (AISI 304)
Stage casing	Chrome-nickel steel 1.4301 EN 10088 (AISI 304)
Wear ring	PTFE
Impeller	Chrome-nickel steel 1.4301 EN 10088 (AISI 304)
Casing cover	Chrome-nickel steel 1.4301 EN 10088 (AISI 304)
Spacer sleeve	Chrome-nickel steel 1.4301 EN 10088 (AISI 304)
Pump shaft	Chrome-nickel steel 1.4401 EN 10088 (AISI 316)
Plug	Chrome-nickel steel 1.4305 EN 10088 (AISI 303)
Mechanical seal with seat according to ISO 3069-KU	Ceramic alumina, carbon, EPDM (Other materials on request)

Special features on request

- Pump with Victaulic ports (MXH-V).
- Pump with flanged ports (MXH-F).
- Other voltages.
- Frequency 60 Hz (as per 60 Hz data sheet).
- Protection IP 55.
- Special mechanical seal
- Seal rings in FPM.
- Higher or lower ambient temperatures.

Coverage chart $n \approx 2900$ rpm

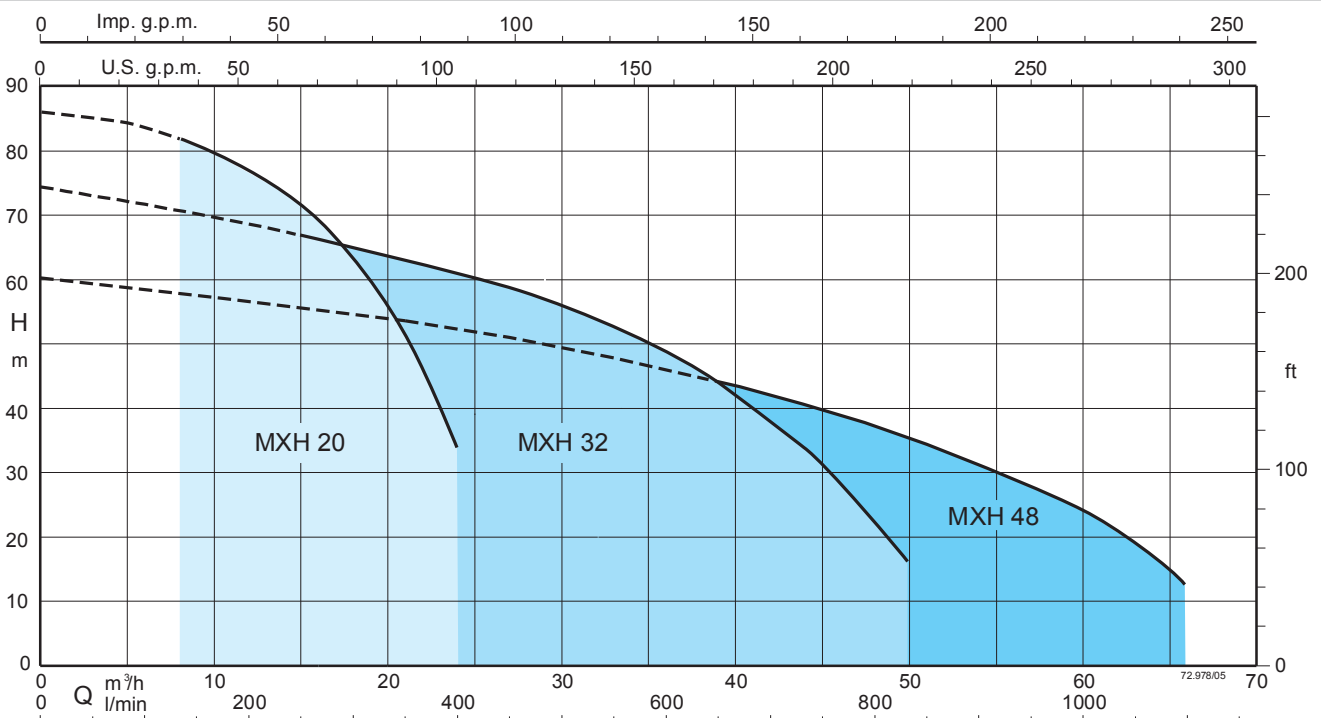

Pumps with frequency converter

The MXH EI pumps are available with power from 1,1 kW up to 7,5 kW, the pumps are equipped with I-MAT installed on board which allows to realize a variable-speed system extremely compact and efficient, ideal in applications of water supply and in the distribution of hot and cold water.

The pump is equipped with transducers suitable for operation and is already programmed at the factory.

Advantages

- Energy saving
- Compact design
- Easy to use
- Programmable to suit the system requirements
- Reliability

Costruction

The system comprises of:

- Pump
- Induction motor
- I-MAT Frequency converter
- Motor adapter for the motor mounting of the frequency converter
- Connection cable between frequency converter and induction motor
- Transducers

Main features

Rated motor power output from 1,1 kW to 7,5 kW

Control range from 1750 to 2900 rpm (2-pole)

Protection against dry running

Protection against operations with closed valve ports

Protection against system leakages

Protection against overcurrent in the motor

Protection against overvoltage and undervoltage of the power supply

Protection against current unbalances between phases

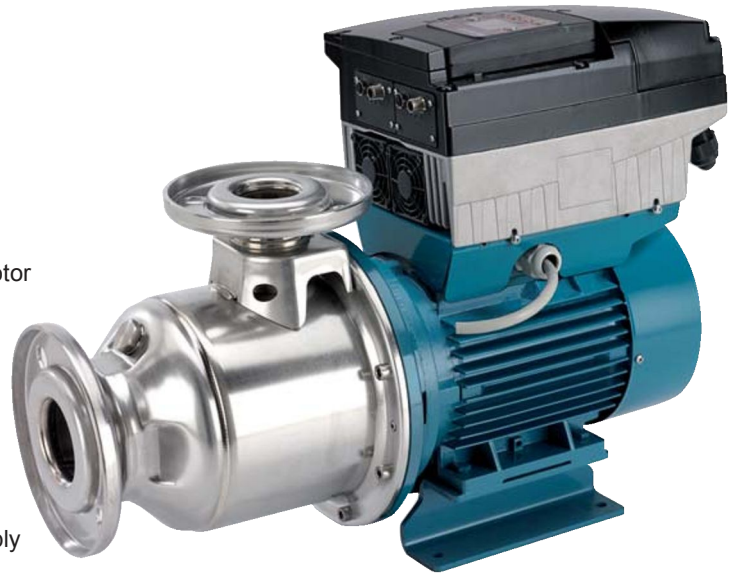

Operating modes



Constant pressure mode
with pressure transducer

In this mode, the system maintains the preset pressure when the flow required by the installation changes.

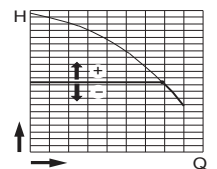

Proportional pressure mode
with pressure transducer

In this mode the system changes the working pressure according to the required flow rate.

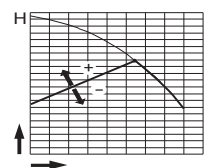

Constant flow mode
with flow meter

In this mode the system maintains a constant flow rate value in a point of the installation according to the required pressure.

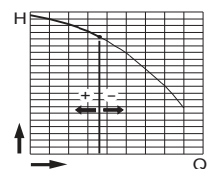

Fixed speed mode
with setting of the speed preferential rotation.

In this mode, by changing the working frequency, you may choose any operational curve included within the working range.

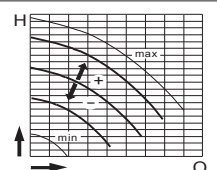

Constant temperature mode
with temperature transducer

In this mode the system keeps the temperature constant inside a system by changing the speed of the pump.

Performance n ≈ 2900 rpm

3 ~	230 V		400 V		P ₂		Q	m³/h											
	A	A	kW	HP	l/min	0		8	10	12	14	16	18	20	22	24			
MXH 2001/A	4,6	2,7	1,1	1,5	H m	17,6	15,7	15,1	14,4	13,5	12,4	11,1	9,5	7,6	5,4				
MXH 2002/A	7,5	4,3	1,8	2,5		35,1	31,4	30,3	29,1	27,5	25,6	23,4	20,6	17,4	13,6				
MXH 2003	11,5	6,6	3	4		54	48,5	46,9	45,2	43,2	40,8	37,7	33,8	28,8	22,3				
MXH 2004/A	-	9,6	4	5,5		71,5	64,5	62,5	60,5	57,5	54,5	50	45	38	29				
MXH 2005	-	10,8	5,5	7,5		89	81,5	79	76	72,5	68	63	56,5	48,5	36				

3 ~	230 V		400 V		Q	m³/h											
	A	A	kW	HP		l/min	0	15	21	24	27	30	33	36	39	44	50
MXH 3201/B	9,2	5,3	2,2	3	H m	18,4	16,3	15,3	14,8	14	13	12	10,8	9,3	6	-	
MXH 3202/B	-	9,6	4	5,5		37	33	31	30	28,5	27	25	23	20,5	15	7,5	
MXH 3203/A	-	10,8	5,5	7,5		55,5	50	47	45,5	43	40,5	38	35	31	23	10	
MXH 3204/A	-	14,3	7,5	10		74,5	67	63	61	59	56	53	49	44	34	16,5	

3 ~	230 V		400 V		Q	m³/h											
	A	A	kW	HP		l/min	0	21	27	33	39	45	48	51	54	60	66
MXH 4801/A	11,5	6,6	3	4	H m	20	18	17	16	14,5	12,5	11,5	10,5	9,5	7	-	
MXH 4802/A	-	10,8	5,5	7,5		41	35,3	33	30,5	27,5	24,5	22,5	21	19	14	7,5	
MXH 4803/A	-	14,3	7,5	10		60,5	53	50	46	42,5	38	35	32,5	29	22,5	16	

P₂ Rated motor power output. Test results with clean cold water, without gas content. + 0,5 m security margin on NPSH-value is necessary.
Tolerances according to UNI EN ISO 9906:2012

Dimensions and weights

Threaded ports
MXH

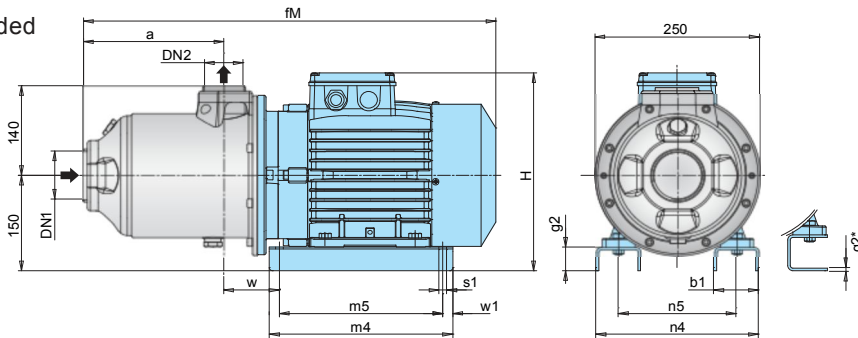

TYPE	DN1	DN2	mm												kg
			ISO 228		fM	a	H	m4	m5	n4	n5	w1	b1	s1	
MXH 2001/A	G 2	G 1 1/2	467	127	280	205	175	170	130	15	54	10	95	6*	26
MXH 2002/A	G 2	G 1 1/2	507	127	280	205	175	170	130	15	54	10	95	6*	30
MXH 2003	G 2	G 1 1/2	540	146	290	205	175	180	140	15	54	10	112	6*	38
MXH 2004/A	G 2	G 1 1/2	574	180,5	290	205	175	180	140	15	54	54	112	6*	39
MXH 2005	G 2	G 1 1/2	630,5	215	310	280	250	258	190	15	68	68	84	38	50,5
MXH 3201/B	G 2 1/2	G 2	503,5	123	280	205	175	170	130	15	54	10	95	6*	29,4
MXH 3202/B	G 2 1/2	G 2	517,5	123	290	205	175	180	140	15	54	10	112	6*	38,5
MXH 3203/A	G 2 1/2	G 2	584,5	169	310	280	250	258	190	15	68	12	84	38	50
MXH 3204/A	G 2 1/2	G 2	630,5	215	310	280	250	258	190	15	68	12	84	38	57,5
MXH 4801/A	G 3	G 2 1/2	547,5	138,5	290	205	175	180	140	15	54	10	128,5	6*	38
MXH 4802/A	G 3	G 2 1/2	568,5	138,5	310	280	250	258	190	15	68	12	100	38	49,5
MXH 4803/A	G 3	G 2 1/2	630,5	200	310	280	250	258	190	15	68	12	100	38	58

Flanges* EN 1092-2

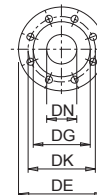

DN	DE	DK	DG	Holes	
				N.	Ø
40	150	110	81	4	19
50	165	125	99	4	19
65	185	145	118	4	19
80	200	160	132	8	19

* ASME 150 lb (ex ANSI 150 lb)

Victaulic ports
MXH-V

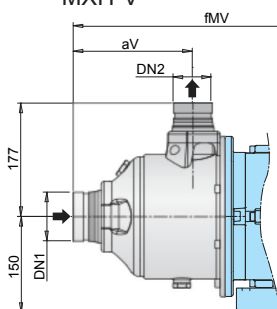

TYPE	DN1	DN2	mm	
			fMV	aV
MXH-V 3201/B	76,1 (DN65)	60,3 (DN50)	541	160
MXH-V 3202/B	76,1 (DN65)	60,3 (DN50)	555	160
MXH-V 3203/A	76,1 (DN65)	60,3 (DN50)	622	206
MXH-V 3204/A	76,1 (DN65)	60,3 (DN50)	668	252
MXH-V 4801/A	88,9 (DN80)	76,1 (DN65)	585	175
MXH-V 4802/A	88,9 (DN80)	76,1 (DN65)	606	175
MXH-V 4803/A	88,9 (DN80)	76,1 (DN65)	668	237

Flanged ports
MXH-F

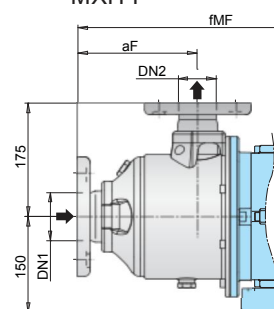

TYPE	DN1	DN2	mm	
			fMF	aF
MXH-F 2001/A	50	40	502	161,5
MXH-F 2002/A	50	40	542	161,5
MXH-F 2003	50	40	575	180,5
MXH-F 2004/A	50	40	624	215
MXH-F 2005	50	40	665	249,5
MXH-F 3201/B	65	50	531	151
MXH-F 3202/B	65	50	545	151
MXH-F 3203/A	65	50	612	197
MXH-F 3204/A	65	50	658	243
MXH-F 4801/A	80	65	565	156
MXH-F 4802/A	80	65	586	156
MXH-F 4803/A	80	65	648	218

Dimensions and weights

Threaded ports
MXH EI

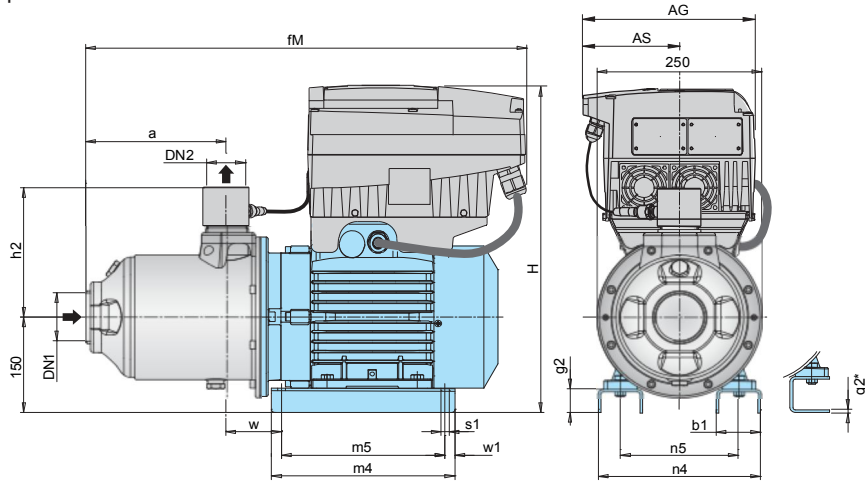

TYPE	DN1 ISO 228	DN2	mm														kg	
			fM	AG	AS	a	H	h2	m4	m5	n4	n5	w1	b1	s1	w		g2
MXH EI 2001/A	G 2	G 1 1/2	499	190	105	127	436	192	205	175	170	130	15	54	10	95	6*	32,4
MXH EI 2002/A	G 2	G 1 1/2	532	210	118	127	436	192	205	175	170	130	15	54	10	95	6*	36,4
MXH EI 2003	G 2	G 1 1/2	572	210	118	146	444	192	205	175	180	140	15	54	10	112	6*	45,5
MXH EI 2004/A	G 2	G 1 1/2	606	210	118	180,5	444	192	205	175	180	140	15	54	54	112	6*	46,5
MXH EI 2005	G 2	G 1 1/2	630,5	210	118	215	472	192	280	250	258	190	15	68	68	84	38	65,3
MXH EI 3201/B	G 2 1/2	G 2	528,5	210	118	123	436	197	205	175	170	130	15	54	10	95	6*	35,8
MXH EI 3202/B	G 2 1/2	G 2	594,5	210	118	123	444	197	205	175	180	140	15	54	10	112	6*	46,0
MXH EI 3203/A	G 2 1/2	G 2	594,5	210	118	169	472	197	280	250	258	190	15	68	12	84	38	64,8
MXH EI 3204/A	G 2 1/2	G 2	665,5	281	153	215	518	197	280	250	258	190	15	68	12	84	38	72,3
MXH EI 4801/A	G 3	G 2 1/2	579,5	210	118	138,5	444	202	205	175	180	140	15	54	10	128,5	6*	45,5
MXH EI 4802/A	G 3	G 2 1/2	568,5	210	118	138,5	472	202	280	250	258	190	15	68	12	100	38	64,3
MXH EI 4803/A	G 3	G 2 1/2	665,5	281	153	200	518	202	280	250	258	190	15	68	12	100	38	72,8

Flanged ports
MXH-F EI

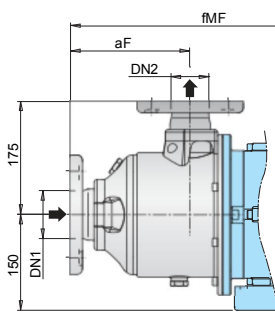

TYPE	DN1 mm	DN2 mm	mm	
			fMF	aF
MXH-F EI 2001/A	50	40	534	161,5
MXH-F EI 2002/A	50	40	567	161,5
MXH-F EI 2003	50	40	607	180,5
MXH-F EI 2004/A	50	40	641	215
MXH-F EI 2005	50	40	665	249,5
MXH-F EI 3201/B	65	50	556	151
MXH-F EI 3202/B	65	50	622	151
MXH-F EI 3203/A	65	50	622	197
MXH-F EI 3204/A	65	50	693	243
MXH-F EI 4801/A	80	65	597	156
MXH-F EI 4802/A	80	65	586	156
MXH-F EI 4803/A	80	65	683	218

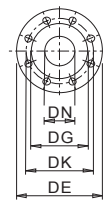

Flanges* EN 1092-2

DN	DE	DK	DG	Holes	
				N.	Ø
40	150	110	81	4	19
50	165	125	99	4	19
65	185	145	118	4	19
80	200	160	132	8	19

* ASME 150 lb (ex ANSI 150 lb)

Characteristic curves n ≈ 2900 rpm

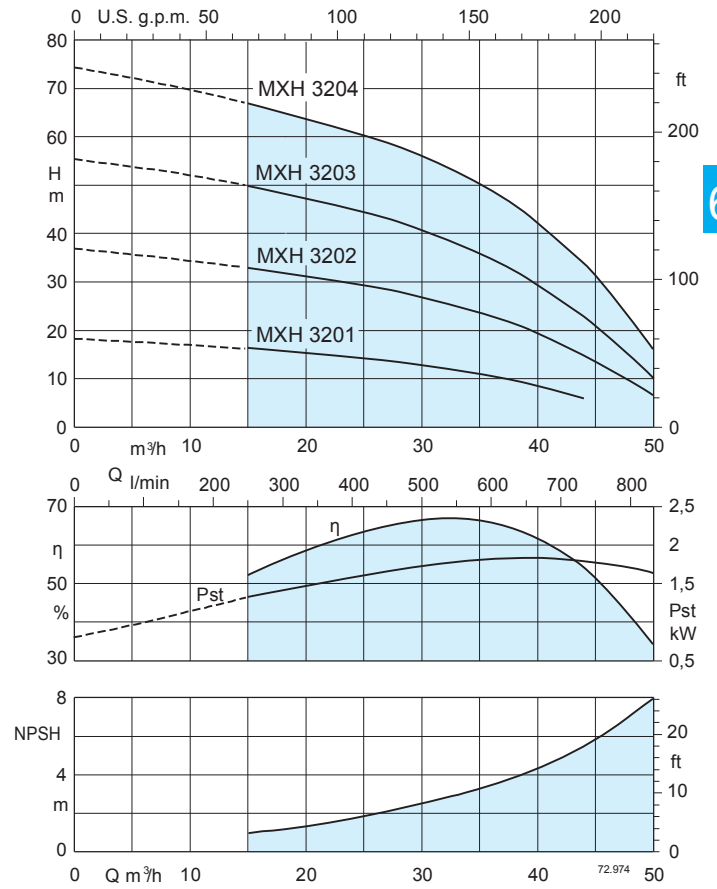
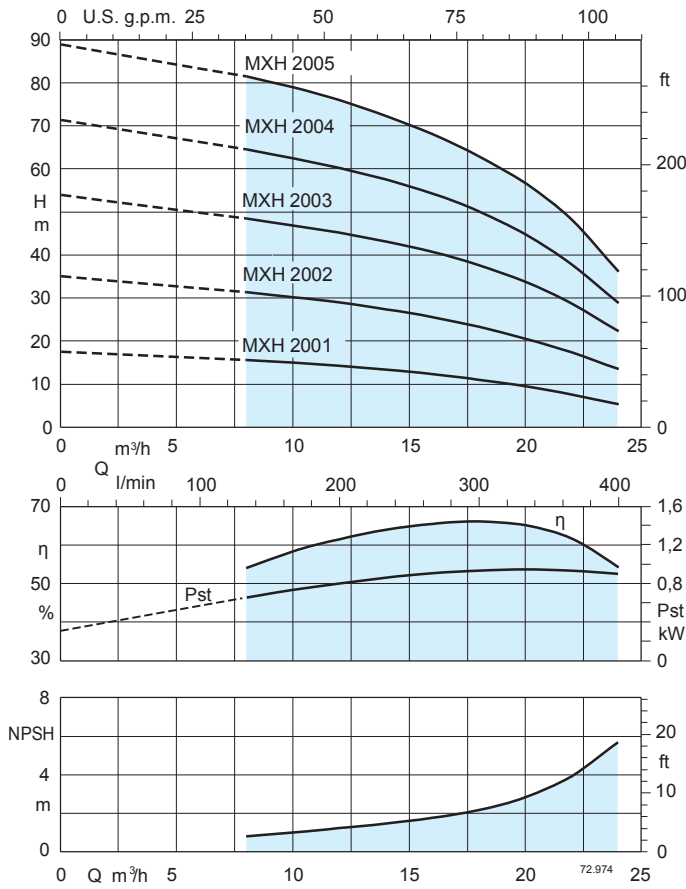

6.2

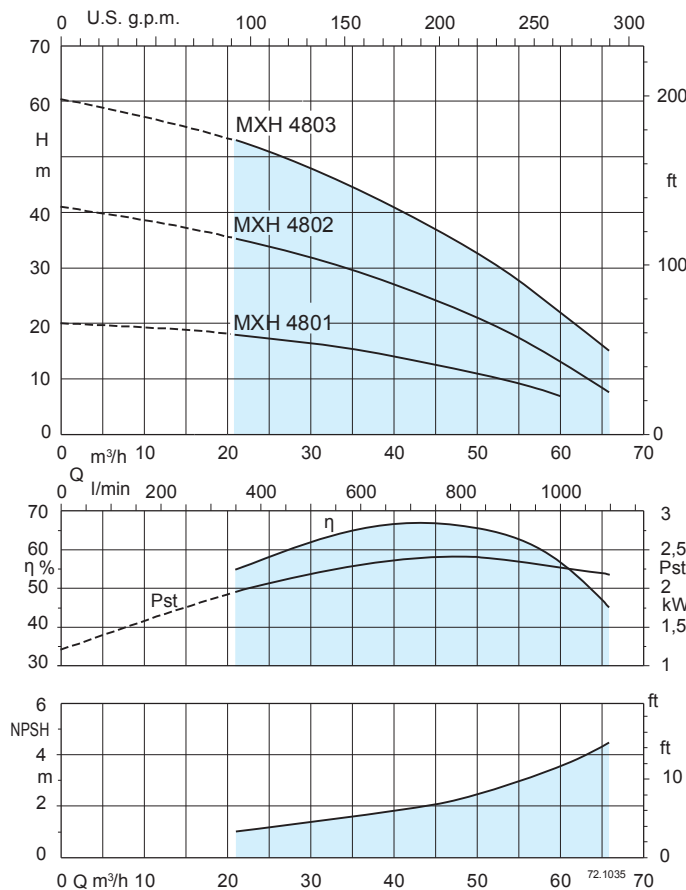

Designation

MXH-F EI 3204 *

- Series _____
- No code = threaded ports _____
- Victaulic ports _____ V
- Flanged ports _____ F
- With frequency converter I-MAT _____
- Rated capacity in m³/h _____
- Number of stages _____
- Construction variants
special seal code (no code = standard seal) _____

Features

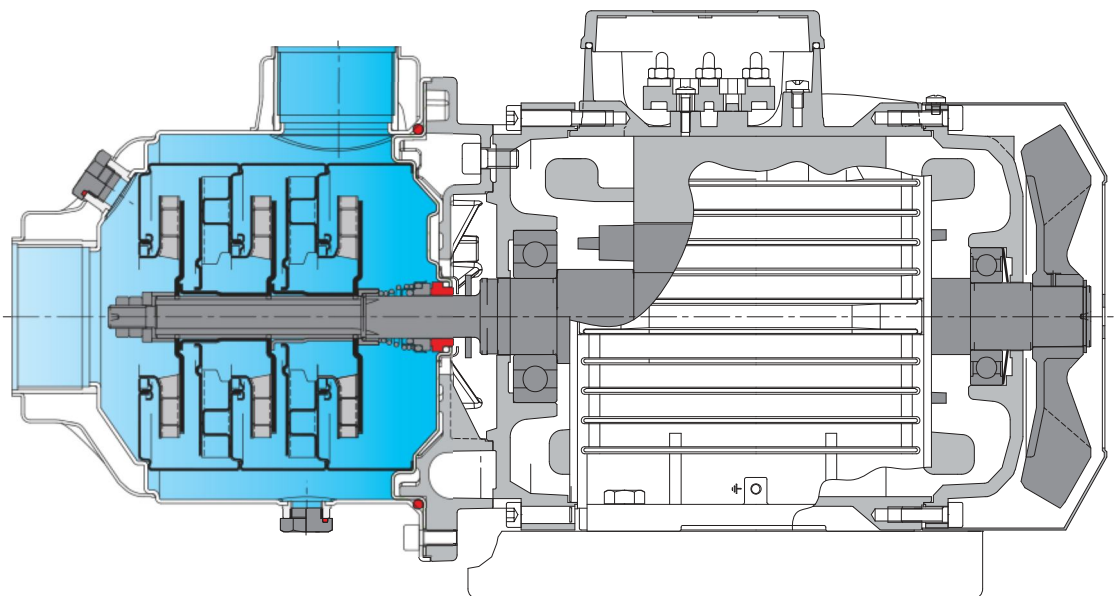

Flexibility

Three versions of ports: threaded, flanged and Victaulic.

Extra safety

With front axis suction port for optimum suction conditions.

Reliable

All hydraulic parts in contact with the pumped liquid are made in stainless steel.
For liquids from -15 °C to 110 °C.

Robust

Single-piece, thick barrel casing, open on one side only, with reinforced threaded ports.

Compact

The bracket between pump and motor is extremely compact.

Greater protection

Against leakage, with the pump casing cover separated from the motor shield.
Possibility of inspecting the seal through the side apertures between the two walls.