

Application

Submersible sludge pumps are intended for pumping water being polluted with content of sludge, clay, sand, grit and similar stuffs with abrasive effects, with total content of impurities up to 30 volume percent.

Max. temperature of pumped liquid 40 °C
Max. density of pumped liquid 1,200 kg.m⁻³
Values pH ranging from 5 to 7.5 pH
Max. submersion of pump-set 10 m

Besides their vertical position those pumps may work also in both horizontal and inclined ones.

It is of advantage to use them in civil engineering, with excavation and melioration works, liquidation of flood consequences, e.g. drainage of flooded cellars, basements, etc.

Those pumps are not suitable for pumping water with content of oils and hydrocarbons.

Construction

Pumps are of single-stage type, close-coupled to an electric motor. Rotor is supported on rolling-contact bearings, grease-lubricated. In the motor winding there are bimetallic thermal receptors built-in, to protect it against damage.

To prevent water penetration from the hydraulic part the electric motor is protected with a mechanical seal being provided with continuous oil closure and lubricated from an oil pool.

Material options

Pump main parts are available in following constructional materials:

Impeller	- special steel
Shaft	- stainless steel
Impeller nut	- stainless steel
Casing, external bolts	- stainless steel

Major part of the pump constructional details is produced of light aluminium-base alloy and steel rubbered pressed pieces, with appreciable mechanical ruggedness.

Version of arrangement

Pump of the KDFU type application may be enlarged with series connection of two pumps for so called „cascade pumping“. There emergency conditions may come to being if the only one pump was not successful in getting a higher delivery head over.

However, cascade connection requires a smaller technical modification of one of those pumps. For that situation there is a set of respective parts available - a modified suction cover and a short connection hose with a quick-coupler.

Cascade pumping may be realized on the condition that a greater part of the total delivery head comes to the upper pump, otherwise, there irregularity of its operation and reduction of its capacity may happen due to the upper pump suction effect.

Accessories and equipment

1. Connecting cable in length of 15 m.
2. Discharge fire hose in length of 20 m provided with half-couplings - on types 65-KDFU and 80-KDFU+. On series 100-KDFU and 125-KDFU there the hose is attached to a discharge elbow with the aid of couplings and the other end is provided with a screw joint.
3. Assembly tools containing nut wrenches, barrel spanners with handles and a hook spanner for a quick-coupler, or discharge hose screw joint.
4. Another hydraulic part of with the pump of series 80-KDFU containing the impeller of dia. 130 mm and a suction cover (on request).

Informatory sectional arrangement

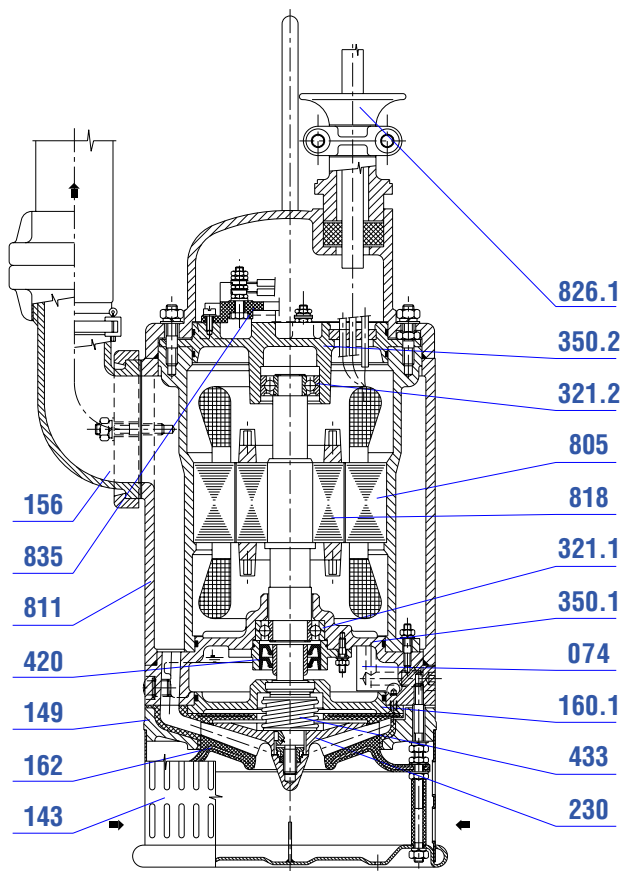

CASCADE CONNECTION

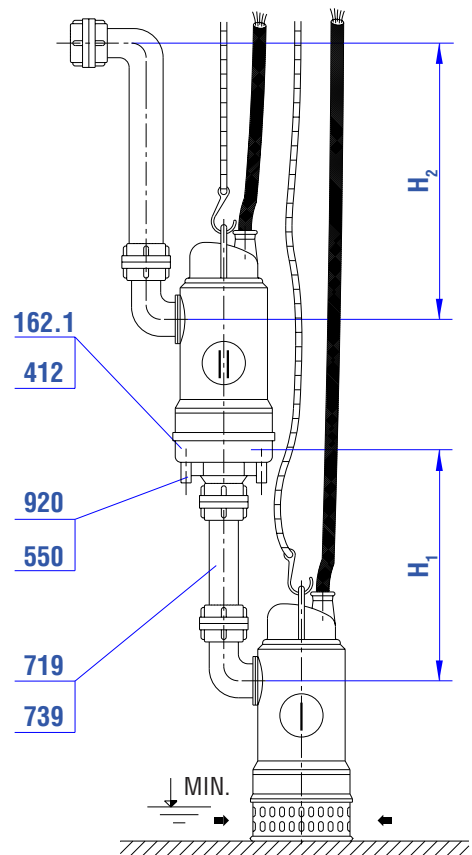

Numbering of items according to DIN 24 250

074 Oil charge
143 Suction strainer
149 Diffuser
156 Discharge elbow
160.1 Oil pool bottom
162 Suction cover
162.1 Suction cover
230 Impeller

321.1 Lower bearing
321.2 Upper bearing
350.1 Lower bearing housing
350.2 Upper bearing housing
412 Cover sealing
420 Radial lip seal
433 Mechanical seal
550 Washer 8,4

719 Complete connecting hose, 1 m
739 Quick-coupler
805 Electric motor stator
811 Stator casing
818 Electric motor rotor
826.1 Cable bushing
835 Terminal board
920 Nut M8

Pump selection chart

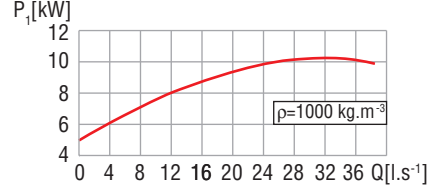
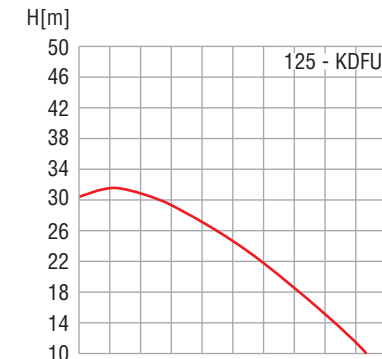
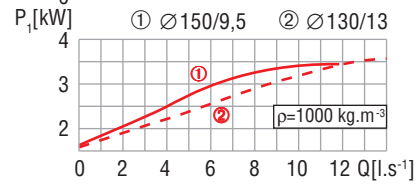
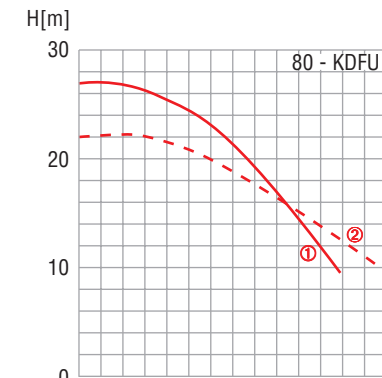
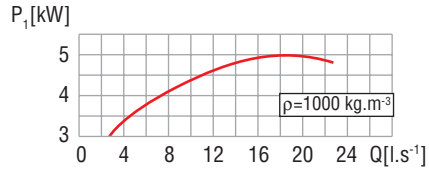
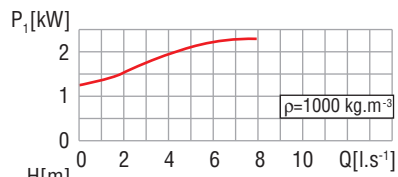
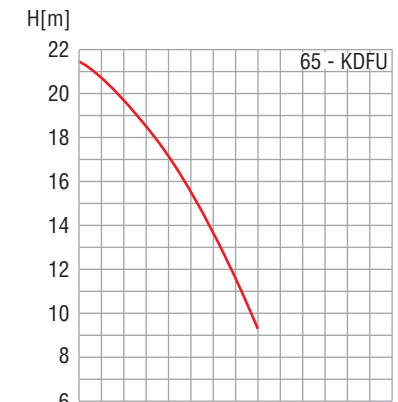

Submersible pumps KDFU

Performance data

Pump type		65-KDFU	80-KDFU	100-KDFU	125-KDFU
Impeller		open, multi-vaned			
Pump passages	∅ (mm)	5			
Impeller diameter	- as standard (mm) - on request (mm)	130 -	150 130	150 -	170 -
Electric motor		single-purpose			
Rated power output	P ₂ (kW)	1,5	3	3	10
Insulation and covering		F; IP 68 ∇ 10 m			
Voltage	- as standard U (V) - on request U (V)	400 -	400 500	400 -	400 -
Frequency	f (Hz)	50			
Number of phases		3			
Cut-out current, max.	- with voltage 400 V I (A) - with voltage 500 V I (A)	4 -	7,5 6	9 -	19 -
Speed of rotation	n (min ⁻¹)	2800	2800	2800	2800
Connecting cable HO7 RN-F		6G1,5			6G2,5
Discharge branch	- as standard DN (mm) - on request DN (mm)	52	75 -	110 52	-
Weight inclusive of cable	m (kg)	32	43	48	90

Pumps must be protected against overloading. For values of cut-out current see the Table.

Dimensions

65-KDFU + 80-KDFU

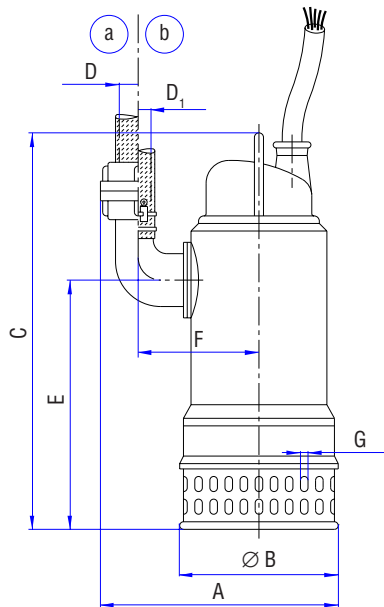

100-KDFU + 125-KDFU

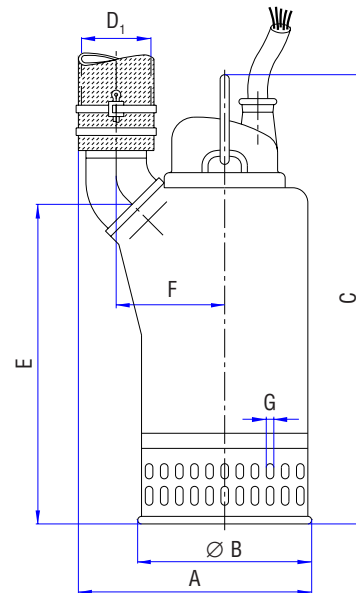

Series	Discharge connection version	~ A	B	~ C	D	D ₁	~ E	~ F	G
65-KDFU	a	330	235	600	DN 52	-	330	160	4
	b	305			-	DN 52			
80-KDFU	a	390	265	650	DN 75	-	370	163	4
	b	325			-	DN 52			
100-KDFU	-	380	265	720	-	DN 110	410	190	4
125-KDFU	-	412	320	800	-	DN 110	545	193	8